

Solaris for Cellulosic Pretreatment

Solaris direct steam injection (DSI) Hydroheaters play a key role in biochemical pretreatment processes. The Solaris sufficiently hydrolyzes and opens up the structure of lignin-based biomass feedstocks to allow efficient and effective enzyme hydrolysis of the hemicellulosic sugars.

These demanding pretreatment methods typically involve a wide range of difficult process conditions:

- Medium consistency feedstocks
- High temperature rises
- Rapid heat transfer
- High pressures and low pH

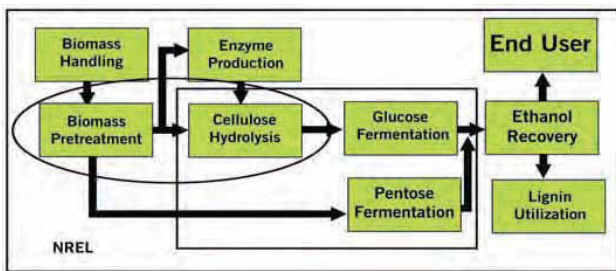

Typical biochemical pretreatment process

Ideal for Medium Consistency Feedstocks

The straight-through patented design of the Solaris is ideal for thick slurries and high fiber content common to a wide variety of biomass feedstocks. Solaris utilizes internally modulated high velocity steam which eliminates clogging and plugging.

Depending on the pretreatment process, Solaris can be designed and constructed around specific process conditions, such as high temperature, low pH and high pressures, while maintaining its key advantages:

- No plugging or stock build-up
- Large temperature rise
- Near-instantaneous heat transfer
- Precise temperature control
- Process stability

From pilot lab research projects to full-scale commercial plant operations, there is a full range of Solaris models for all cellulosic ethanol applications.



Solaris heats virtually any biomass:

- » Plant and crop residue
- » Whole stillage
- » Pulp & paper mill residue
- » Fruit residue
- » Food & beverage waste
- » Wood residues
- » Wastewater sludge

- A** stock inlet
- B** steam diffuser
- C** stock outlet
- D** steam inlet
- E** stem plug

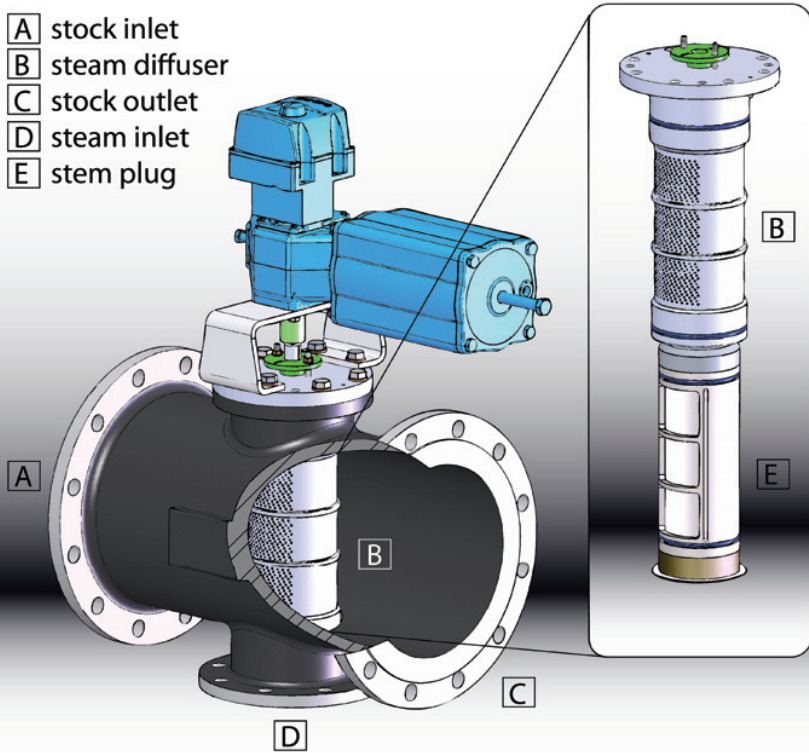

How the Solaris® Works

Biomass feedstock enters the heater (A), flows past the diverter and steam diffuser (B) and is discharged at the outlet (C). Full pressure steam enters at inlet (D) and travels up through the steam plug (E). Rotation of the stem plug controls steam flow.

To achieve precise temperature control, steam is metered into the stock at sonic or near-sonic velocity by exposing a multitude of small diffuser holes. Steam pressure and velocity remain constant for:

- No plugging or stock build-up
- Large temperature rise
- Near-instantaneous heat transfer
- Precise temperature control
- Process stability

From pilot lab research projects to full-scale commercial plant operations, there is a full range of Solaris models for all Cellulosic ethanol applications.

Standard Product and Specifications

- Pressure/Temperature Rating: 195/300psig @ 450°F [13.4/20.7 bar at 232°C]
- Body Material: Stainless steel 316L
- Internal Wetted Parts: Stainless steel 316L or similar
- Connections: ANSI Class 150, ANSI Class 300, or PN 10/16
- Actuator: Fisher diaphragm actuator with integral positioner
- Size Range: 2" to 32" diameter
- Viscosity Range: 1 to 40,000 cP
- Solids Concentration: 0.5 to 13% typical



Compliances

- Designed to ASME B31.1
- CE/PED and CRN available upon request